

ADJUST TO FINISHED GRADE WITH APPROVED RUBBER EXTENSION RINGS, MAXIMUM 12". UTILIZE ADHESIVE BETWEEN EXTENSION RINGS. INSTALL RAM-NEK PLASTIC GASKET BETWEEN BOTTOM RING AND PRECAST TOP SECTION AND BETWEEN TOP RING AND MANHOLE FRAME.

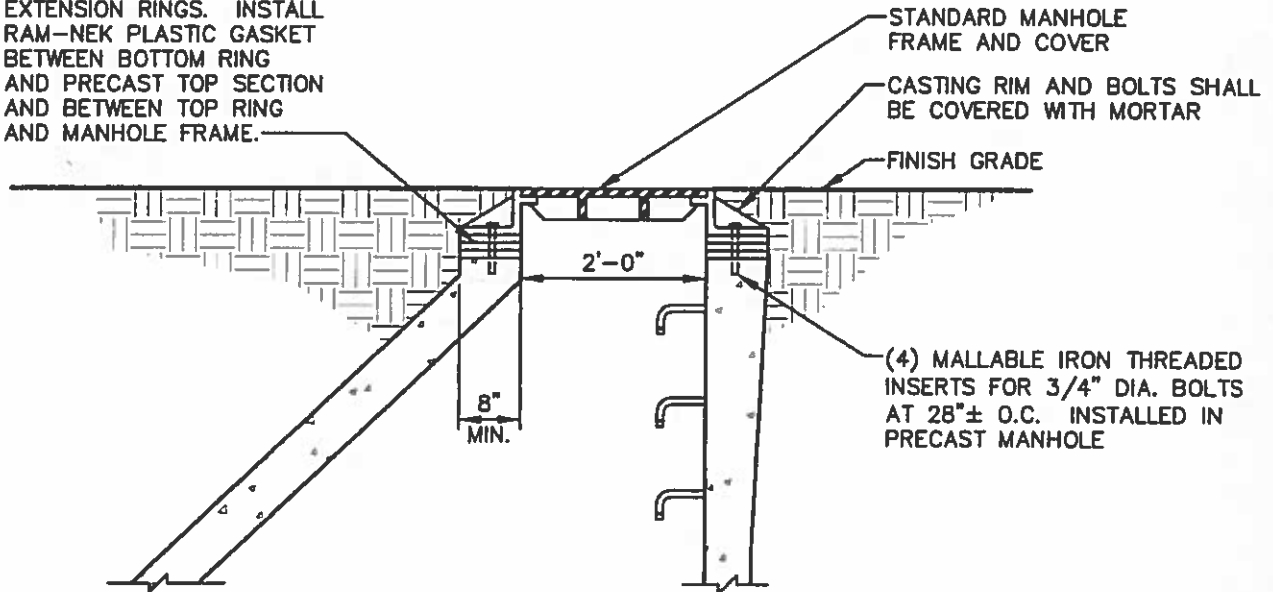

**MANHOLE FRAME ADJUSTMENT**  
NOT TO SCALE

MANHOLE FRAME ADJUSTMENT

SPRING - BENNER - WALKER  
JOINT AUTHORITY

DATE  
11/5/21

SCALE  
NTS

PROJECT

SHEET  
7